

PolyGard® Carbon Monoxide CO Transmitter ADTX3 1110

DESCRIPTION

CO transmitter including digital measurement value processing and temperature compensation for the continuous monitoring of the ambient air to detect carbon monoxide concentrations (CO). Comfortable calibration routine with selective access release is integrated in the transmitter. The ADT-03 possesses a standard analog output (0) 4- 20 mA or (0) 2– 10 V DC, and an RS-485 interface. 2 relays with adjustable switching thresholds are available as an option.

APPLICATION

For the detection of carbon monoxide (CO) within a wide range of commercial applications such as underground garages, tunnels, engine repair shops, loading bays, engine test benches, shelters, go-kart race courses etc. Due to the 4 to 20 mA output signal the CO transmitter is compatible to the PolyGard series MGC/DGC by MSR-E as well as to any other electronic control or automation system.



Standard enclosure



FEATURES

- Digital measurement value processing incl. temperature compensation.
- Continuous monitoring
- Low zero point drift
- Good stability to poisoning
- Long life sensor
- Modular plug-in technology
- Easy maintenance
- Comfortable calibration with selective access release
- Reverse polarity protected, overload and short-circuit proof
- (0) 4 - 20 mA / (0) 2 – 10V analog signal output, selectable
- Serial interface RS-485 (optional ModBus, BacNet MS/TP)
- IP65 protection
- Manual calibration via potentiometer (option)
- Manual addressing for RS-485 mode (option)
- 4 – 20 mA analog input for external transmitter (optional)
- Approved according to EN 61010-1; ANSI/UL 61010 1; CAN/CSA-C22.2 No. 61010-1
- Relay output (optional)
- Integrated buzzer (optional)
- LED flashlight (optional)
- LCD display (optional)
- LED status display (optional)
- Heating (optional)
- Duct mounting (optional)

SPECIFICATIONS

General sensor performance

Detected gas	Carbon monoxide (CO)
Sensor element	Electrochemical, diffusion
Measuring range: - Standard	0 – 300 ppm
- Optional	50 – 2000 ppm
Pressure range	Atmospheric ± 10 %
Humidity range	15 – 90 % RH non-condensing
Storage temperature	5 °C to 30 °C (41 °F to 86 °F)
Storage time	6 months
Mounting height	1.5 to 1.8 m (5 – 6 ft.)
Sensor coverage	465 m ² , (5,000 sq.ft.), to 930 m ² (10,000 sq.ft.) “ideal conditions” assumed

Type ADT03-1110

Accuracy	± 3 ppm	
Repeatability	± 3 % of reading	
Long term zero-point drift	< 5% signal loss/year	
Response time	t ₉₀ ≤ 50 s	
Sensor life expectancy	5 years, normal operating environment	
Humidity range: Short-time	0 – 95 % RH non-condensing	
Working temp.: Continuous	-10 °C to + 50 °C (14 °F to 122 °F) w/o heating	
Working temp.: Short-time	-20 °C to + 50 °C (-4 °F to 122 °F) w/o heating	
Cross sensitivity*	Concentration (ppm)	Reaction (ppm)
Acetone, C ₃ H ₆ O	1000	0
Acetylene, C ₂ H ₂	40	80
Ammonia, NH ₃	100	0
Carbon dioxide, CO ₂	5000	0
Chlorine, Cl ₂	2	0
Ethanol, C ₂ H ₅ OH	2000	5
Hydrogen, H ₂	100	20
Hydrogen Sulphide, H ₂ S	25	0
Iso Propanol, C ₃ H ₈ O	200	0
Nitric oxide, NO	50	8
Nitrogen dioxide, NO ₂	50	-1,0
Sulphur dioxide, SO ₂	50	< 0.5

Type ADT53-1110

Accuracy	± 1 ppm	
Repeatability	± 2 % of reading	
Long term sensitivity output drift	< 2% signal loss/month	
Response time	t ₉₀ ≤ 40 s	
Sensor life expectancy	3 years, normal operating environment	
Working temp.: Continuous	-10 °C to + 45 °C (14 °F to 113 °F) w/o heating	
Working temp.: Short-time	-20 °C to + 50 °C (-4 °F to 122 °F) w/o heating	
Cross sensitivity*	Concentration (ppm)	Reaction (ppm)
Sulphur dioxide, SO ₂	50	0
Hydrogen Sulphide, H ₂ S	25	0
Nitrogen dioxide, NO ₂	50	0
Nitric oxide, NO	50	0
Hydrogen, H ₂	100	< 60

* The table doesn't claim to be complete. Other gases, too, can have an influence on the sensitivity. The mentioned cross sensitivity data are only reference values valid for new sensors.

GAS ALARM SYSTEMS

Electrical	
Power supply	18 - 28 VDC/AC, (reverse polarity protected)
Power consumption (without options)	22 mA, max. (0.6 VA)
Output signal	
Analog output signal	(0) 4 – 20 mA, load \leq 500 Ω ,
Selectable: Current / tension	(0) 2 - 10 V, load \geq 50 k Ω
Starting point 0 / 20 %	proportional, overload and short-circuit proof
Serial interface	
Transceiver	RS 485 or BacNet MS/TP / 19200 Baud (9600 at Mod_Bus)
Physical characteristics	
Enclosure Plastic Type A*	Polycarbonate
Flammability	UL 94 V2
Enclosure colour*	RAL 7032 (light grey)
Dimensions (W x H x D)	94 x 130 x 57 mm (3.7 x 5.12 x 2.24 inch.)
Weight	Approx. 0.5 kg (1.1 lbs.)
Protection class	IP 65
Installation	Wall mounting
Cable entry	Standard 1 x M 20
Wire connection	Screw type terminal, min. 0.25 mm ² (24 AWG) max. 2.5 mm ² (14 AWG)
Wire distance	Current signal: ca. 500 m (1500 ft) Voltage signal: ca. 200 m (600 ft.)
Certificates	
	VDI 2053 German air treatment systems for car parks (pending)
Guidelines	
	EMC Directives 2004/108/EC EN 61010-1:2010 ANSI/UL 61010-1 CAN/CSA-C22.2 No. 61010-1 CE
Warranty	One year on material (without sensor)
Options	
Relay output	
Alarm relay 1	30 VAC/DC, 0,5 A, potential-free, SPDT
Alarm relay 2	30 VAC/DC, 0,5 A, potential-free, SPNO/SPNC
Power consumption	30 mA, (max 0.8 VA)
Warning buzzer	
Acoustic pressure	85 dB (distance 300 mm) (1 ft)
Frequency	3.5 kHz
Power consumption	30 mA, (max 0.8 VA)
LCD Display	
LCD	Two lines, each 16 characters
Power consumption	10 mA, (max 0.3 VA)
LED display	
Green-yellow-red	Supply, low alarm, high alarm
Power consumption	10 mA, (max. 0.3 VA)
Heating	
Temperature controlled	3 °C \pm 2°C (37.5 °F \pm 3.6 °F)
Ambient temperature	- 40 °C (- 40 °F)
Power consumption	0.3 A; 7.5 VA
Analog Input	
Only for RS-485 mode	4 – 20 mA overload and short-circuit proof, input resistance 200 Ω
Power supply for external transmitter	24 VDC max. 50 mA

*For further enclosure types see datasheet ADT Enclosure.

GAS ALARM SYSTEMS

ORDERING INFORMATION

ADT-03-1110-X-XXXXXXXXXX

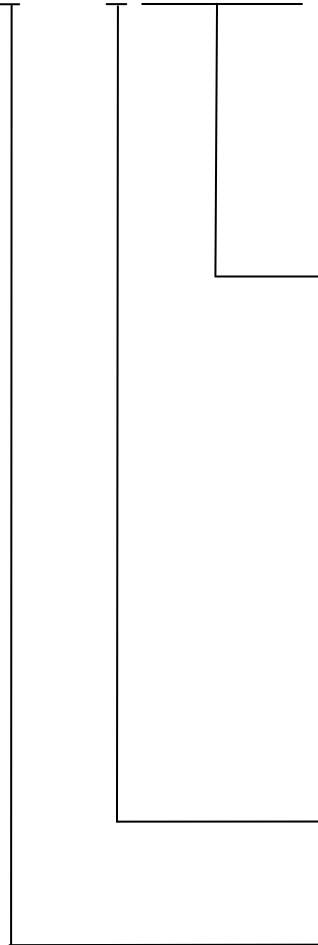

Options

1XXXXXXXX	Relay output ²
X1XXXXXXXX	Buzzer int.
X2XXXXXXXX	Flashlight (LED)
X3XXXXXXXX	Warning buzzer and flashlight
XX1XXXXXXXX	Heating
XXXX1XXXX	RS- 485 protocol for DGC-05 series
XXXX2XXXX	RS- 485 protocol ModBUS
XXXX3XXXX	RS- 485 protocol customers' specification
XXXX4XXXX	BacNet MS/TP
XXXXDXXXX	MSR_D_Bus protocol
XXXXX1XXX	Calibration / addressing mode tool
XXXXX2XXX	Manual calibration
XXXXX3XXX	Manual addressing
XXXXX4XXX	Manual calibration / addressing
XXXXXX1XX	LCD display ³
XXXXXX2XX	LED status display ^{2,3}
XXXXXXX1X	4 – 20 mA analog input
XXXXXXX1	Factory calibration 0 - 300 ppm
XXXXXXX2	Factory calibration 0 - 150 ppm
XXXXXXX3	Factory calibration 0 - 200 ppm
XXXXXXX4	Factory calibration 0 - 100 ppm
XXXXXXX5	Factory calibration 0 - 50 ppm
XXXXXXX6	Factory calibration 0 - 400 ppm
XXXXXXX7	Factory calibration 0 - 500 ppm
XXXXXXX8	Factory calibration 0 - 1000 ppm
XXXXXXX9	Factory calibration 0 - 2000 ppm
XXXXXXXXA	Factory calibration 0 - 250 ppm

Enclosure¹

A	Plastic enclosure
B	Duct mounting
5	Stainless steel

Sensor Type

0	Sensor Type ADT03-1110
5	Sensor Type ADT53-1110

¹ See Data sheet "PolyGard ADT Enclosure"

² Please indicate thresholds for low and high alarm when ordering.

³ Not in connection with stainless steel housing

Example: CO transmitter, Sensor type ADT03-1110, stainless housing, tool mode, factory calibration 0 - 300 ppm

Ordering No.: ADT-03-1110-5-XXXXX1XX1

CONNECTING DIAGRAM

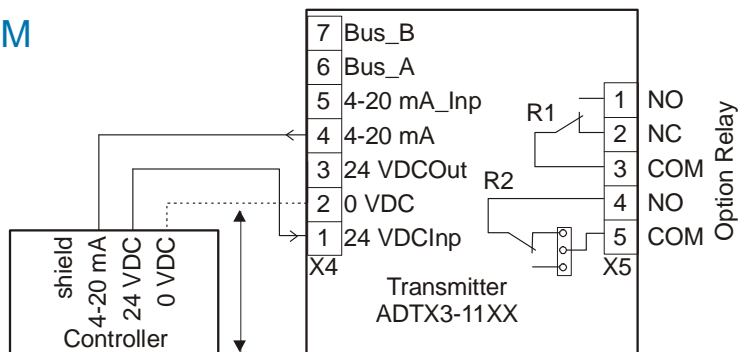

0 VDC: Two wire mode only with 4 to 20 mA Output signal

